

MODEL
JH-1600E

Solar Power Inverter

INSTALLATION & OPERATION MANUAL

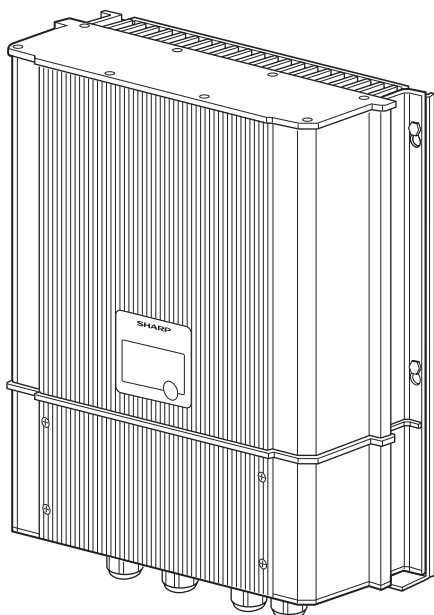

	Page
• IMPORTANT SAFETY INSTRUCTIONS	1
Conventions Used	1
General Safety Precautions for Installation	1
• Introduction	2
Outline of Grid-Interactive Home PV System	2
• Dimensions	3
Solar Power Inverter.....	3
Mounting Bracket.....	4
Unpacking Carton Box.....	4
• Installation	5
Planning the Installation	5
Inverter Location.....	5
• Installing Solar Power Inverter	6
Mount the Solar Power Inverter	7
• Wiring Solar Power Inverter	9
Before wiring.....	10
Removing the Front Panel.....	11
Solar Power Inverter Wiring Overview.....	12
• Connecting to DC Disconnect	13
• Connecting to AC Disconnect	15
• Test Run	18
Checking the PV Array DC Voltage.....	18
Checking the AC Utility Voltage.....	18
Starting Up the Inverter	18
• Monitoring the Inverter	19
Display Panel.....	19
Status Indicator Lights.....	19
Monitoring the Front Display.....	20
Emergency Stop	22
Restart	22
• Specification	23
Electrical Specification.....	23
Environment Specification	23
Mechanical Specification	23
How to Set Parameter	24
Checking Output Power.....	25

SHARP WARRANTY

Grid Inverter

This Sharp product is warranted against faults in materials and manufacture for a period of sixty (60) months from the date of original purchase.

Such faults will be rectified by Sharp Corporation free of charge by either repair or replacement at Sharp's option when used under normal use and reasonable care in the opinion of Sharp in accordance with the manufacturers instructions.

Sharp Corporation Australia Pty Ltd is not responsible for the costs of any on-site labor and any costs associated with the installation, removal, reinstallation or transportation costs under this limited warranty or for losses due to down time.

THE WARRANTY IS SUBJECT TO:

The unit is installed according to the "Installation Instructions" provided by Sharp.
That the solar power inverter is installed by a licensed electrical contractor in accordance with AS/NZS 5033 Installation of photovoltaic arrays and AS/NZS 3000 Electrical Installations and applicable local electrical service rules.

THIS WARRANTY DOES NOT APPLY:

If the rating plate has been removed, damaged or rendered illegible.
The warranty does not extend to accessories, defects or injuries caused by or resulting from causes not attributed to faulty parts in the manufacture of the product, including but not limited to defect or injury caused by or resulting from, misuse, abuse, neglect, accidental damage, improper voltage, incorrect system design, vermin infestation, storm damage, fire, flood, exposed to corrosive conditions, or any alterations made to the product which are not authorized by Sharp.

Please retain your sales documentation as this should be produced to validate a warranty claim.

This warranty is in addition to and in no way limits, varies or excludes any express and implied rights and remedies under relevant legislation in the country of sale.

SHARP
SHARP CORPORATION OF AUSTRALIA PTY. LIMITED
ABN 40 003 039 405
1 Huntingwood Drive
Huntingwood NSW 2148
SHARP CORPORATION OF NEW ZEALAND LIMITED
58 Hugg Johnstone Drive
Penrose, Auckland

IMPORTANT NOTICE: This warranty applies only to products sold in Australia & New Zealand

SHARP

FOR LOCATION ENQUIRIES WITHIN

AUSTRALIA

REGARDING YOUR LOCAL

SHARP APPROVED SERVICE CENTRE

VISIT OUR WEBSITE AT

www.sharp.net.au

OR CALL SHARP CUSTOMER CARE

1300 135 022

(LOCAL CALL COST APPLY WITHIN AUSTRALIA)

SHARP CORPORATION OF AUSTRALIA PTY LTD

SHARP

FOR LOCATION ENQUIRIES WITHIN

NEW ZEALAND

REGARDING YOUR LOCAL

SHARP APPROVED SERVICE CENTRE

VISIT OUR WEBSITE AT

www.sharp.net.nz

CONTACT YOUR SELLING DEALER/RETAILER
OR CALL

SHARP CUSTOMER SERVICES

TELEPHONE: 09 573 0111

FACSIMILE: 09 573 0113

SHARP CORPORATION OF NEW ZEALAND LIMITED

IMPORTANT SAFETY INSTRUCTIONS



SAVE THESE INSTRUCTIONS

This manual contains important safety instructions that shall be followed during the installation and maintenance of the solar power inverter.

To reduce the risk of electrical shock, and to ensure the safe installation and operation of the solar power inverter, the following words appear throughout this manual to inform you of or alert you to something that may cause a dangerous situation or that safety instructions must be followed.

Conventions Used

The following conventions are used in this guide.

 WARNING	May cause serious injury or death unless the instructions are followed.
 CAUTION	May injure a person or damage equipment unless the instructions are followed.
NOTE	Important information to be followed when installing or using the solar power inverter.

General Safety Precautions for Installation

 WARNING <ul style="list-style-type: none">• This solar power inverter must be installed by a licensed electrical contractor in accordance with:<ul style="list-style-type: none">a) AS/NZS 5033 Installation of photovoltaic (PV) arraysb) AS/NZS 3000 Electrical Installations (know as the Australian/ New Zealand Wiring Rulesc) Applicable local electrical service rules.• Installation by a non licensed person is against the law, and could cause electric shock or severe injury if installed incorrectly. Additionally, your insurance policies and manufacturers warranty will become void and the manufacturer will not liable for any claims.• Correct installation will assist the maximum amount of electricity to be exported to the grid.• To avoid electric shock or burns, always follow all warnings and cautions marked on the solar power inverter, and in this manual.• Ensure that all electrical connections are secure, loose connections can cause overheating, smoke and fire.• This solar power inverter is a grid connect device only, it is not intended for stand alone operation.• Ensure that the AC and DC isolation is switched off before connecting/ disconnecting the inverter.• The surface of the inverter case can become hot during normal operation. In extreme conditions, the inverter chassis can reach temperatures of up to 70°C. To avoid accidental burns; ensure that the inverter is not within reach of children. do not install it in a location where people can accidentally come into contact with the unit.• Install the unit according to the installation instructions paying particular attention to clearances for free air circulation. Installing this device in improper locations may cause overheating, smoke and fire.• Do not cover or impede the free air flow around the unit, this may cause overheating and reduced performance.• Do not disassemble or attempt to repair the unit, disassembling the unit will break the seal and void the manufacturer's warranty.• Do not install the unit on an external wall near the ocean, salt air can cause corrosion.• The inverter does not contain DC or AC isolation switches, these should be provided by the installer.

Introduction

Outline of Grid-Interactive Home PV System

The home PV system is a grid connected type product that includes the following components: PV modules that convert light into DC electricity, a solar power inverter that changes DC electricity into AC and blends the power with the utility, a DC disconnect that breaks the connection between the PV modules and the solar power inverter, and an AC disconnect that breaks the connection between the load center and the solar power inverter. The system is connected to the grid through the AC meter.

1. PV* Module / 2. Mounting Structure

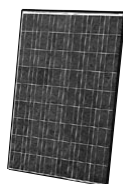

Converts solar energy to electric power.
PV modules are fixed on roof with the mounting structure.

*PV: Photovoltaic

3. Wiring Cables

Connect PV array and the DC disconnect.

PV String: A number of PV modules interconnected electrically in series to produce the required operating voltage.

PV Array: A number of PV modules connected together in a single mounting structure.

4. DC Disconnect

Isolates the PV array from the solar power inverter.

5. Solar Power Inverter

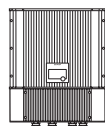

JH-1600E

The solar power inverter converts DC power generated by PV array into AC power, and automatically controls the operation of the system.

6. AC Disconnect

Isolates the AC power from the solar power inverter.

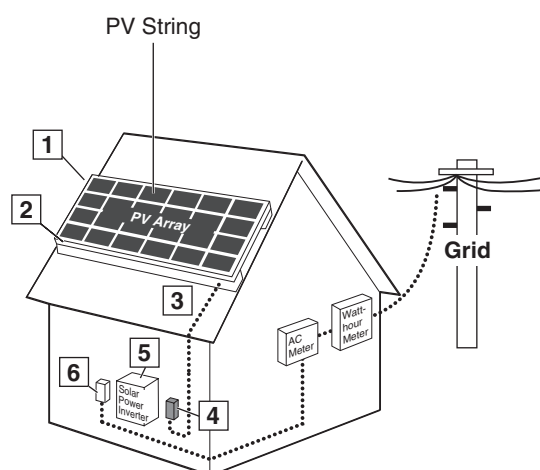

The JH-1600E incorporates anti-islanding in accordance with AS 4777. The JH-1600E has a detector circuit to sense ground faults from the PV array. The JH-1600E also complies with local EMC requirement.

Dimensions

Solar Power Inverter

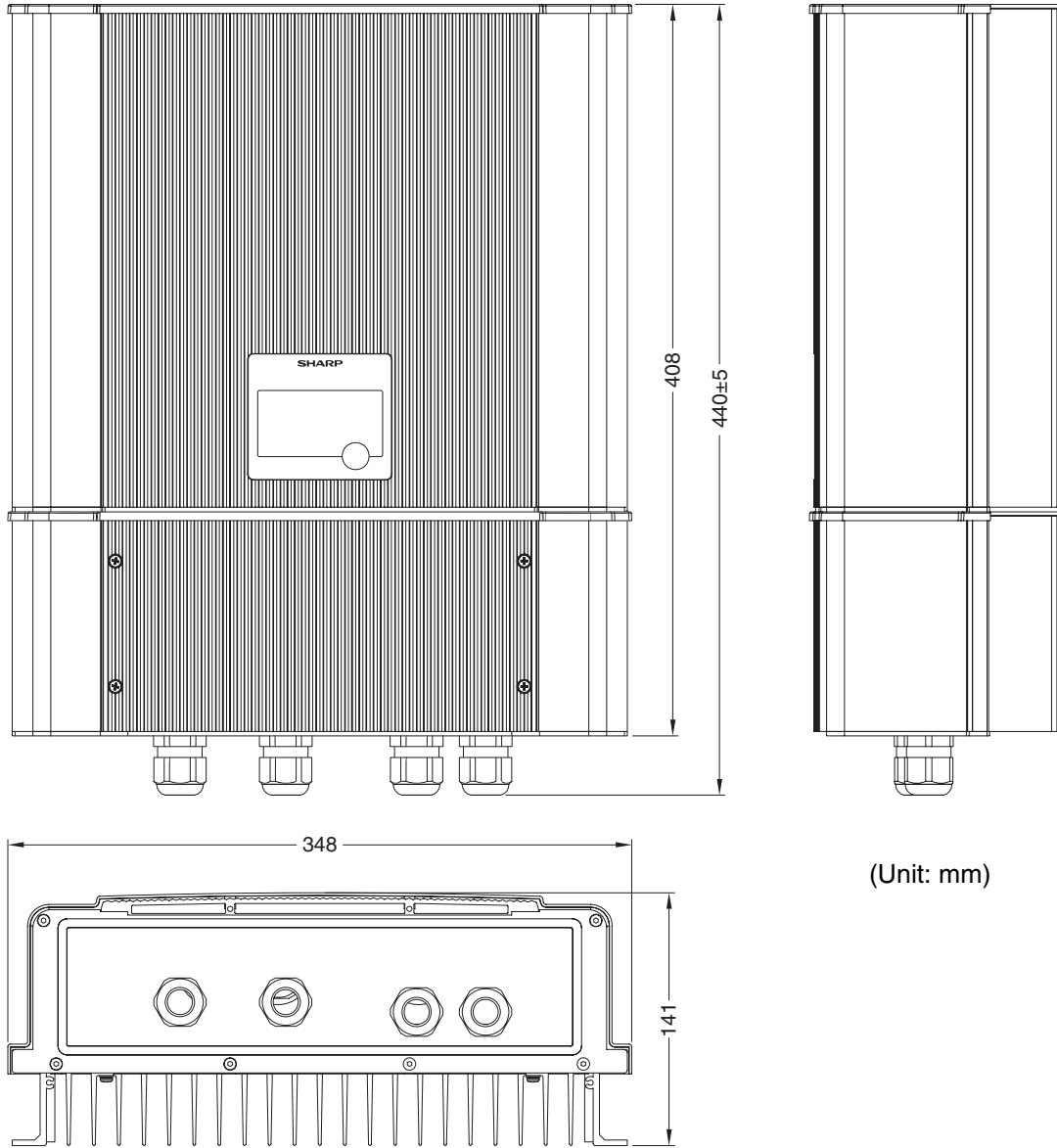

(Unit: mm)

Mounting Bracket

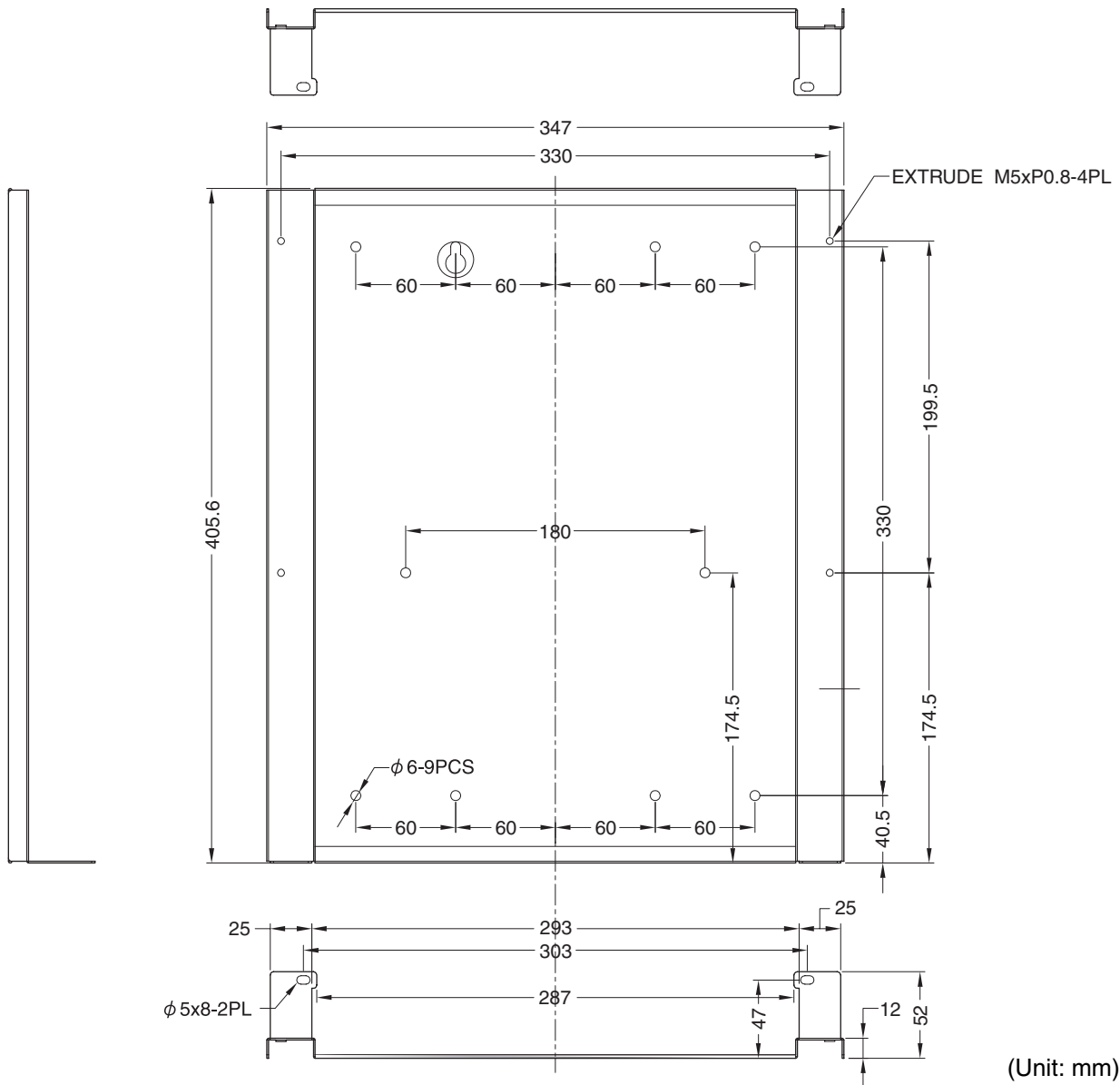

(Unit: mm)

Unpacking Carton Box

Before installation, make sure all the items listed below are included within the carton box.

- Bracket 1 piece
- Installation & operation manual 1 manual
- Inspection report 1 report
- Screws (for the solar power inverter) 2 pieces (#6-32 UNC*10)
- Screws (for the bracket) 10 pieces (ϕ 5.5*1.8*80)

Installation

Planning the Installation

The following issues need to be considered when planning for an installation using the inverter. See the specified sections for detailed.

- Inverter Location (Page 5)
- Installing Solar Power Inverter (Page 6)
- Wiring Solar Power Inverter (Page 9)

Preparing for the Installation

Ensure your electricity provider is consulted for any requirements for connecting to or returning power to the grid. Obtain all permits necessary to complete the installation. Consult your local and national electrical codes for more information.

Inverter Location

The solar power inverter should be installed outdoors except near salt water*. Installation of this device in an improper location may cause smoke or fire danger. Also refer to the *IMPORTANT SAFETY INSTRUCTIONS* section on page 1. For best performance, the inverter should be installed in a cool shady area.

Do not install the solar power inverter in a location:

- Higher than the altitude of about 2,000 m above sea level
- Close to corrosive gas or liquid
- Near salt water*
- Exposed to direct sunlight
- Prone to flooding or high levels of snow pack
- Minimal or no air flow, high humidity or condensation
- Near television antenna or antenna cable

* Salt water: area near the ocean or sea, or less than 0.3 miles from the ocean or sea.

Fire Safety

Do not install anywhere near combustible or flammable materials.

Indoor/Outdoor Orientation

The inverter uses a Type IP65-rated enclosure that can be mounted indoors or outdoors.

The inverter must be mounted vertically on a wall or pole.

Do not mount the inverter horizontally.

Temperature

Ensure that the inverter is mounted in a location where the ambient temperature range is -20°C to +60°C. When the temperature is over +40°C, the inverter may de-rate power.

Installing Solar Power Inverter

⚠ WARNING

WARNING: BURN HAZARD

Do not install in a location where people can accidentally come into contact with the inverter. High temperatures can be present on the inverter, causing a potential burn hazard. In extreme condition, the inverter chassis can reach temperatures about 70°C, which can cause skin burns if accidentally touched. Ensure that the inverter is located away from normal traffic areas.

Inverter failure due to improper installation will void the inverter warranty. Consider the following when determining where to install the inverter.

⚠ CAUTION

- Excessive debris (such as dust, leaves and cobwebs) can accumulate on the unit, interfering with wiring connections and ventilation. Do not install in a location where debris can accumulate (under a tree, for example).
- Make sure that the wall is strong enough to handle the weight of the solar power inverter. Reinforce the wall as required for a secure installation.
- Make sure that ventilation of the solar power inverter is unobstructed. Keep the clearance on the upper of the solar power inverter more than 300 mm, the lower more than 500 mm and the left and right sides more than 150 mm each.
- Make sure that the lower side of the solar power inverter has 1500 mm and the front side has 700 mm clearance for the electrician to operate.
- Make sure that the solar power inverter is installed plumb and level.
- Never install the solar power inverter upside down.
- Never install the solar power inverter horizontally or tilted.

NOTE

To minimize copper losses, the wire lengths between the PV array and the inverter and between the inverter and the Main Utility Service Panel are kept to a minimum. The maximum distances will depend on wire gauges and the PV array output voltages.

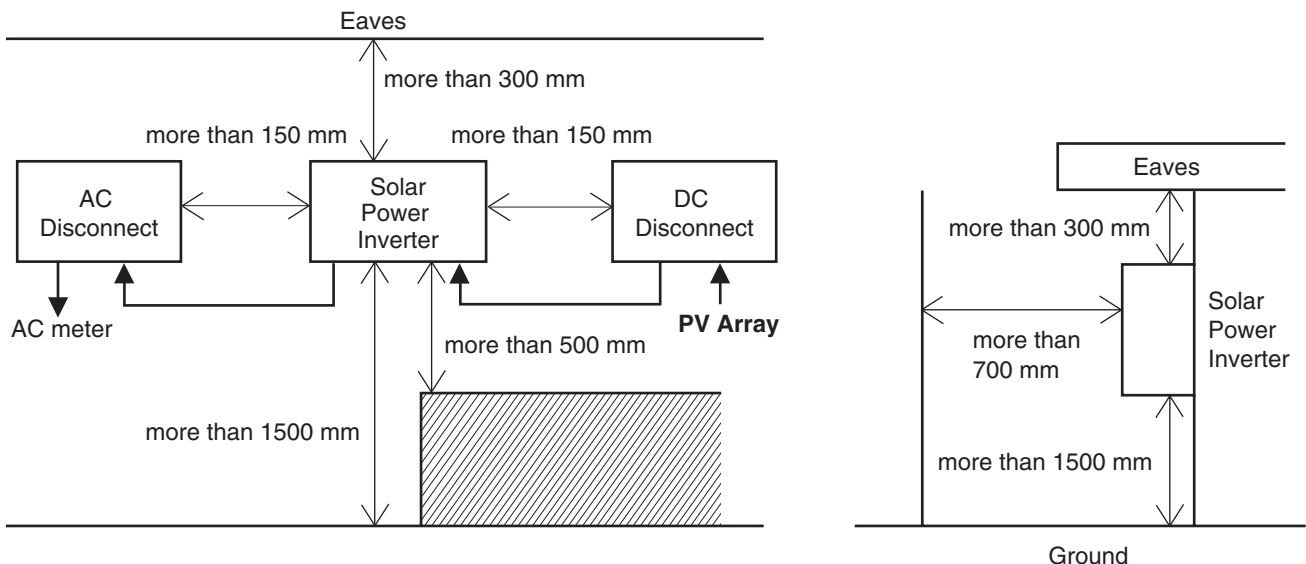

Mount the Solar Power Inverter

Make sure the supporting surface is strong enough to handle 50 kg.

Wall Mount Bracket Dimensions

The dimensions of the mounting bracket are shown in figure below.

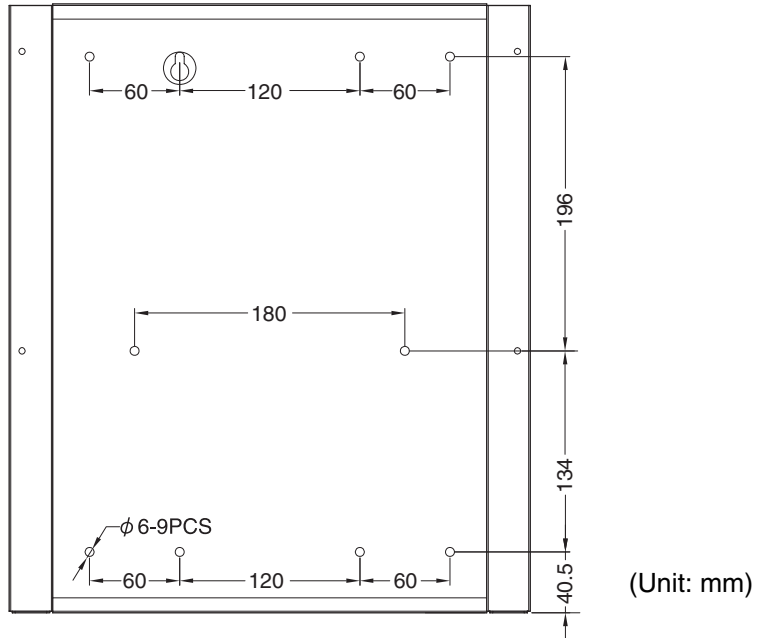

(1) Use 10 pcs screws (ϕ 5.5*1.8*80) to fix the mounting bracket.

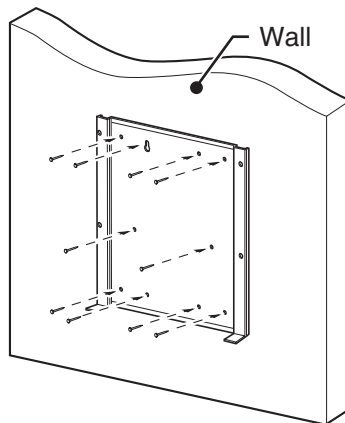

(2) Seal the space between the bracket and the wall with caulking as shown the picture below.

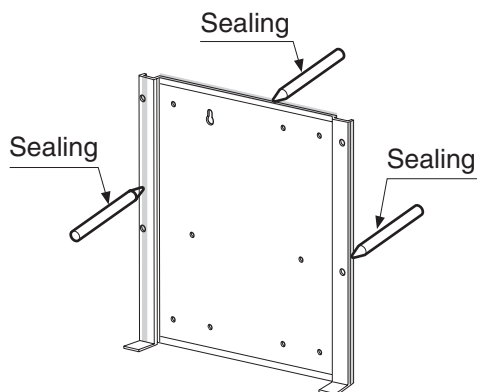

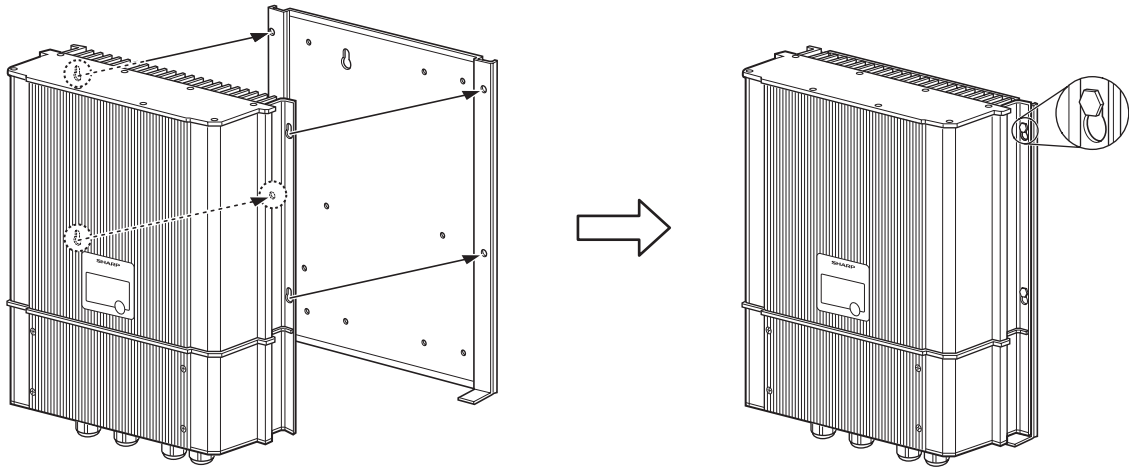

(3) Place the JH-1600E on the mounting bracket. Key holes located on the upper side and middle side of the inverter unit are for hanging the unit on the bracket. place key holes on the 4 hexa bolt head the bracket.

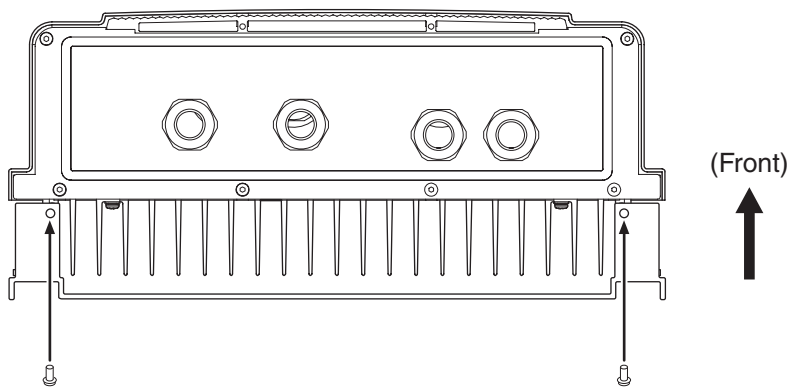

(4) Use 2 pcs screws to fix the JH-1600E on the mounting bracket.



Wiring Solar Power Inverter

 WARNING	<ul style="list-style-type: none"> • All of the procedure must be completed by a qualified electrician. • Wiring the solar power inverter and the DC disconnect enclosure must be performed using electrical conduit. • Completely cover the surface of the entire PV array with an opaques (dark) material before wiring the solar modules. The PV array produces electrical energy when exposed to sunlight and could create a hazardous condition. • To reduce the risk of electrical shock, do not work with wet hands when your body is wet, or in a wet location. • Use low-voltage insulating gloves. • Disconnect the PV array output cable and the module output cable when working, or wear electrical insulated clothing. • To reduce the risk of electrical shock, be sure to turn off the following devices before starting wiring installation: <ul style="list-style-type: none"> - The dedicated circuit breaker for the solar power inverter on the AC meter. - The DC disconnect switch - The AC disconnect switch • Do not turn on the DC and AC disconnect switch until the wiring installation is finished.
 CAUTION	<ul style="list-style-type: none"> • Unused cable opening must be covered. • Grounding installation is the responsibility of the installer. • To avoid the risk of fire or electrical shock, use proper sized wires. • To reduce the risk of short circuits during installation or servicing of the solar power inverter, use insulated tools.
NOTE	<ul style="list-style-type: none"> • All electrical installations shall be done in accordance with all local electrical codes and the Australia Standards. • Wiring the PV module <ul style="list-style-type: none"> - The number of PV modules in series should be determined so that the open circuit voltage of the PV strings is not higher than 350 V_{DC} when the ambient temperature is from -20°C to 40°C, and the minimum operating voltage is higher than 60 V. Refer to the PV manufactures module specifications for voltage/temperature co-efficient. • Confirm that the dedicated breaker for the solar power inverter on the AC meter and the breaker on the AC disconnect are OFF. If they are ON, turn them OFF.

Before wiring

AC Circuit breaker

This breaker must be sized to handle the rated maximum output voltage and current of the inverter. (Please refer to the *Specification* section on page 23.)

Recommended AC circuit breaker:

For JH-1600E: 10 Amps / 250 V_{ac}.

To wire the main utility service panel to inverter:

- (1) Connect the ground wire (green and yellow) from the ground terminal in the main utility service panel to GND (⊕) terminal in the inverter.
- (2) Connect the L (or Line) to Line terminal in the inverter.
- (3) Connect the N (or Neutral) to Neutral terminal in the inverter.
- (4) Ensure all connections are correctly wired and proper torque according to values shown in the table below.

Wire Size (mm ²)	Torque	
	In-lb	Nm
Up to 4	12	1.3

DC cables, isolator fuse

AS per AS/NZS 5033

Removing the Front Panel

Remove the front panel of the solar power inverter.

- (1) Remove the 4 screws from the lower part of the front panel of the solar power inverter. Then remove the front panel.

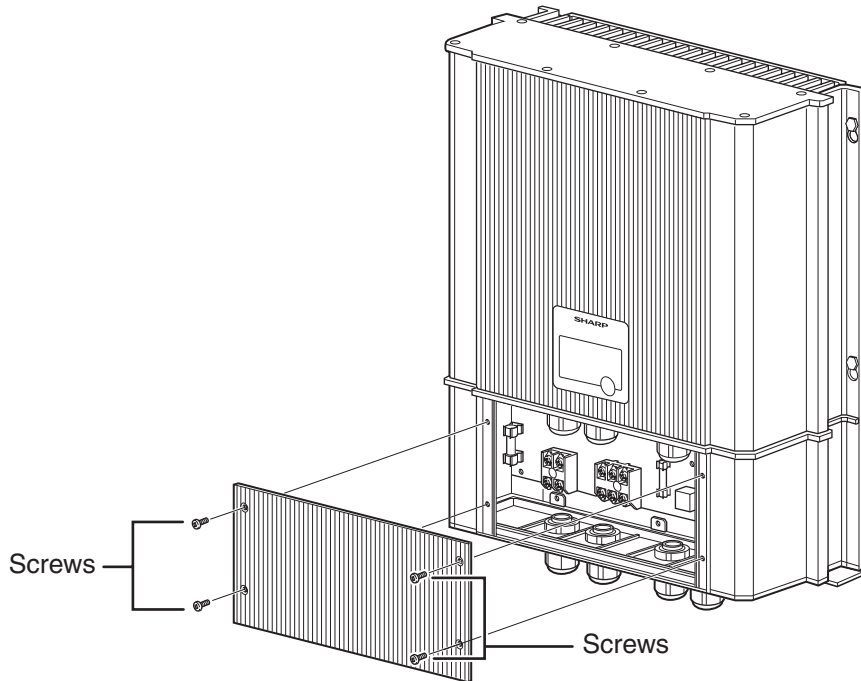

- (2) The four glands shown below should be used for the purpose indicated. If there are any unused or open glands, they should be covered.

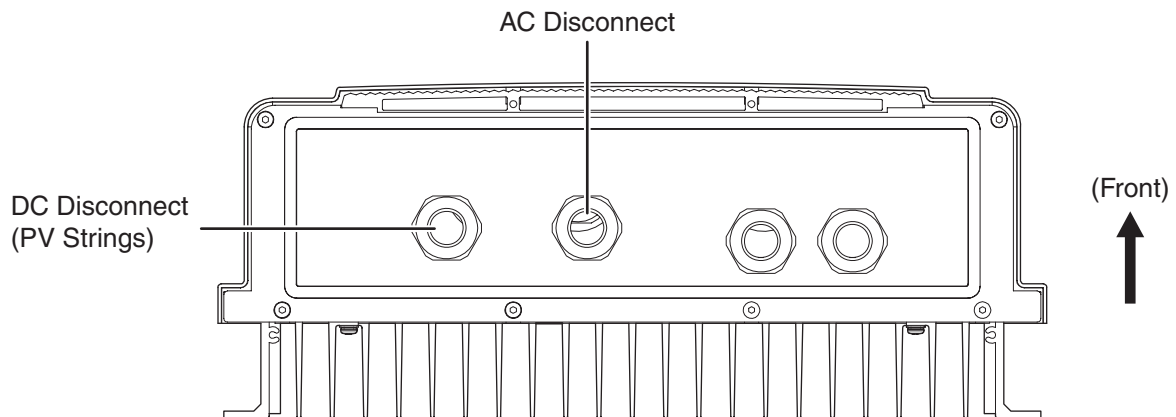

Solar Power Inverter Wiring Overview

 WARNING	WARNING: FIRE, SHOCK AND ENERGY HAZARD Before wiring the inverter, read all instructions and cautionary markings located in this manual, on the PV array, and on the main service panel.
--	--

 CAUTION	CAUTION: Note the polarity of PV cable Black wire = Positive White wire = Negative
--	---

General wiring steps

There are four main steps in the wiring of the inverter:

- (1) **Grounding the PV array (see your PV equipment documentation)**
- (2) **Turning off the DC disconnect and the AC disconnect**
- (3) **Making the DC connections from PV array to the inverter**
- (4) **Making the AC connections from inverter to main utility service panel**

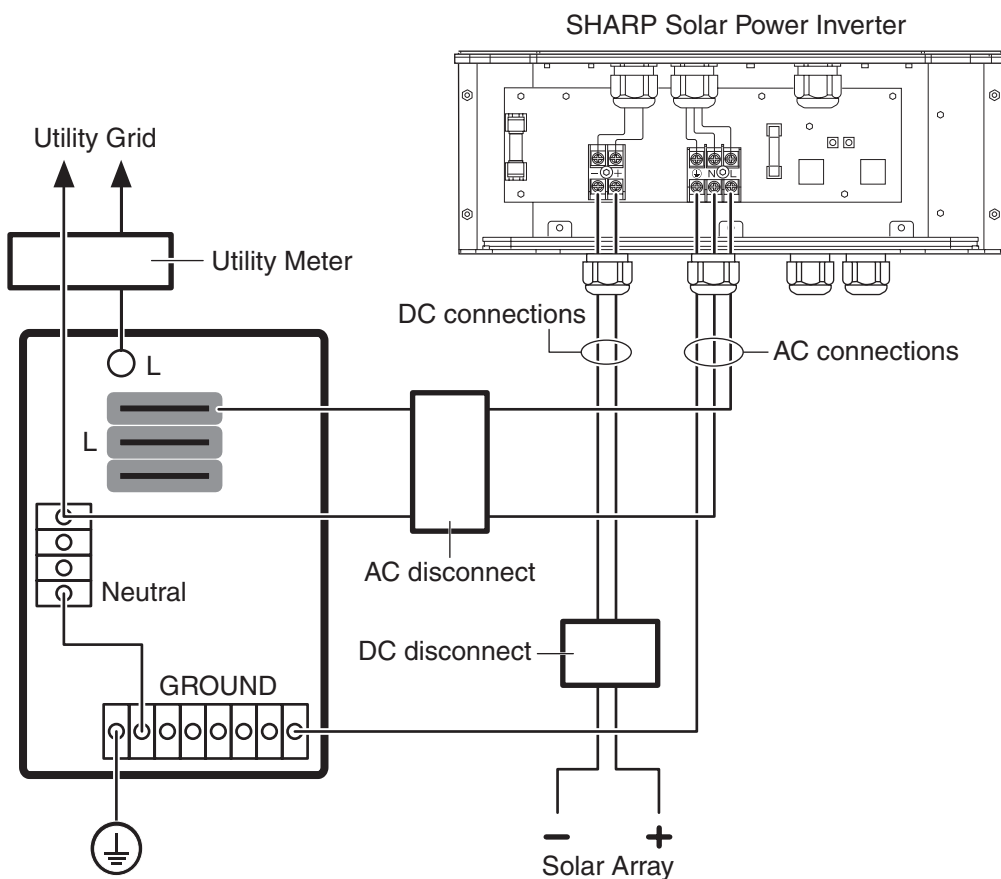

Connecting to DC Disconnect

⚠ CAUTION

Make sure DC disconnect is open.

This section describes the connection between the solar power inverter and the DC disconnect from the PV string.

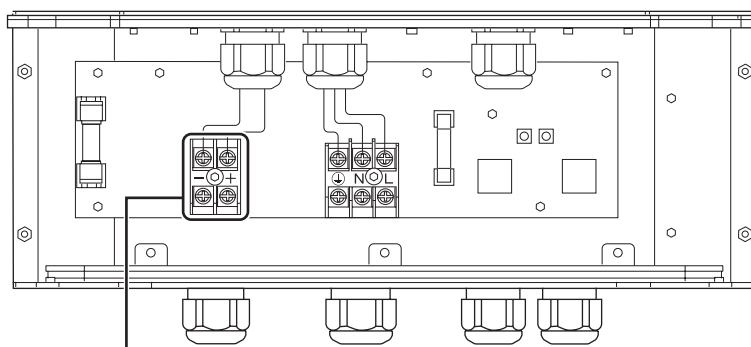

DC terminal block for DC disconnect

Follow all WARNING and CAUTION of Wiring Solar Power Inverter (page 9).

- (1) Install two copper wires (positive and negative) from the DC disconnect through the conduit.**
- (2) Attach a forked spade or lug connector to the cables before connecting to the terminal block.**

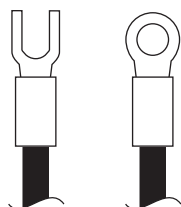

Pass the wire through the gland before connecting to the terminal.

- (3) Connect the black wire to the positive terminal of the terminal block, and tighten the screw firmly to clamp the wire.**

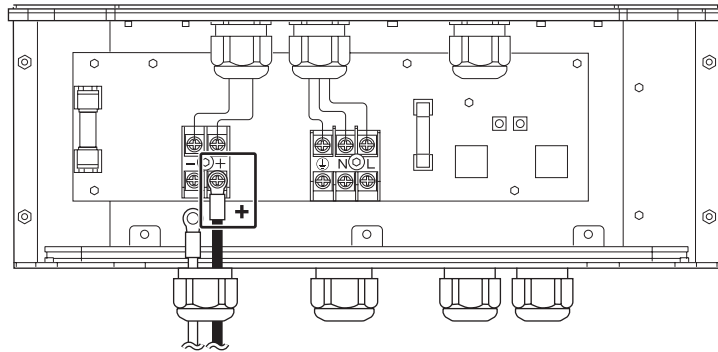

- (4) Attach a forked spade or lug connector to the cables before connecting to the terminal block.**

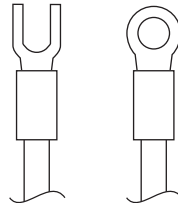

- (5) Connect the white wire to the negative terminal of the terminal block, and tighten the screw firmly to clamp the wire.**

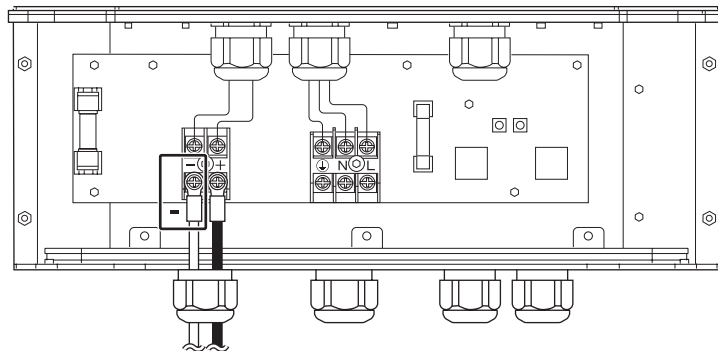

- (6) Confirm all of the wires are correctly and securely connected to the terminals of the solar power inverter.**

⚠ WARNING

WARNING: SHOCK HAZARD

The inverter must be grounded by connection to a grounded permanent wiring system.

Connecting to AC Disconnect

This section describes the connection between the solar power inverter and the AC disconnect. The wires needed are the AC output cable from the solar power inverter (one pair of wires) and the grounding wire.

Follow all WARNING and CAUTION of Wiring Solar Power Inverter (page 9).

⚠ CAUTION

- Make sure AC disconnect is open.
- Use outdoor wiring and conduit on the outdoor section between the solar power inverter and the PV modules.

NOTE

- The AC disconnect includes over current protection.

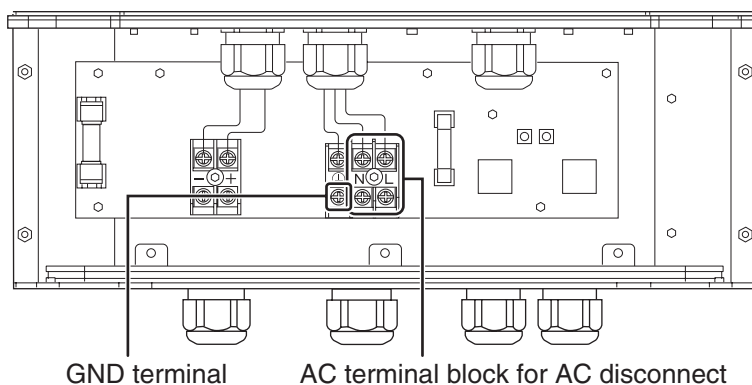

(1) Attach a forked spade or lug connector to the AC cables before connecting to the terminal block.

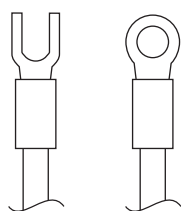

Pass the wire through the gland before connecting to the terminal.

- (2) Connect one wire to the N terminal of the AC terminal block, and tighten the screw firmly to clamp the wire.
Connect the other wire (after performing step 2) to the L terminal, and tighten the screw firmly to clamp the wire.**

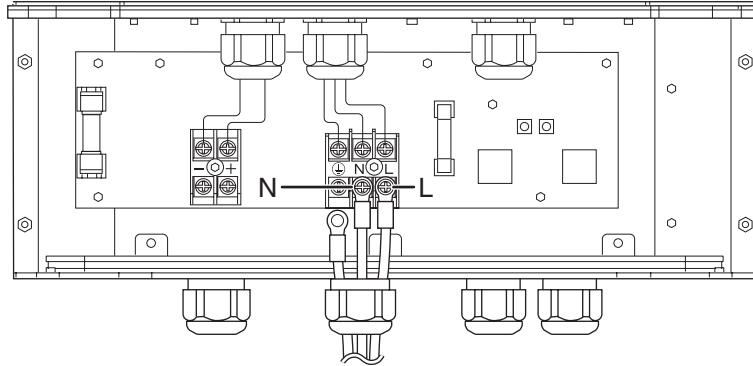

- (3) Connect the grounding wire to the leftmost GND terminal of the AC terminal block, and tighten the screw firmly to clamp the wire.**

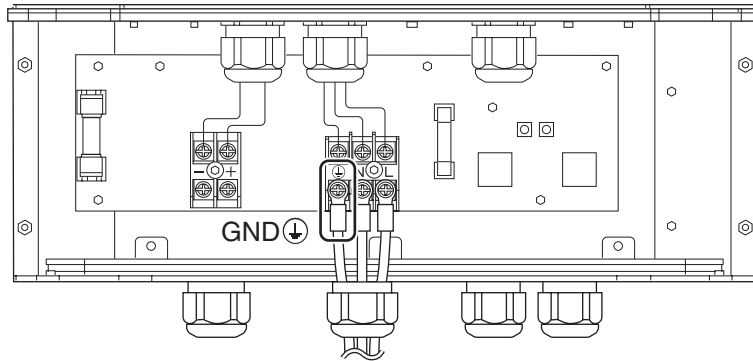

- (4) Confirm that all wires are correctly and securely connected to the terminals of the solar power inverter.
Confirm that all the screws do not move if the connected wires are pulled or bent.
Tighten all the screws firmly again.**

Test Run

Checking the PV Array DC Voltage

To check the PV array DC voltage:

- (1) **Uncover the PV arrays and expose them to full sunlight. The sunlight must be intense enough to produce the required output voltage.**
- (2) **Measure the PV array open circuit DC voltage across the DC positive (+) and negative (-) terminals. This voltage must be greater than 70 Vdc (to energize the electronics) and less than 320 Vdc (should be less than 350 Vdc to prevent damage to the inverter).**

Checking the AC Utility Voltage

To check the AC utility voltage:

- (1) **Switch on the main and inverter breakers in the main electrical service panel.**
- (2) **Using an AC voltmeter, measure the AC open circuit utility voltage between L (Line) and N (Neutral). Ensure the voltage is at approximately the nominal value. The inverter operates with a line-to-neutral voltage range around the nominal value.**

See "Output" section in "Electrical Specification" (page 23) for the utility voltage operating range for your inverter model.

After performing the voltage checks, reattaching all covers that were removed during installation and startup.



WARNING: SHOCK HAZARD
Before reattaching covers, turn OFF the breaker switches in the main utility service panel and disconnect device for PV array.

Starting Up the Inverter

To start up the inverter:

- (1) **Switch the AC disconnection switch (breaker) to the ON position.**
- (2) **Switch the DC disconnection switch (breaker) to the ON position.**
 - The inverter starts up automatically.
 - It takes approximately 1 minute to startup ON-Grid LED (Green) flashes.
- (3) **Check the inverter display. After startup is completed, ON-Grid LED (Green) lights up and output power is displayed on the display panel.**
- (4) **Replace the front panel, pressing up the panel to fit it to the packing (push front panel up to seal and insert screw).**
Tightening torque 6 in-lb (0.7 Nm)

Monitoring the Inverter

Display Panel

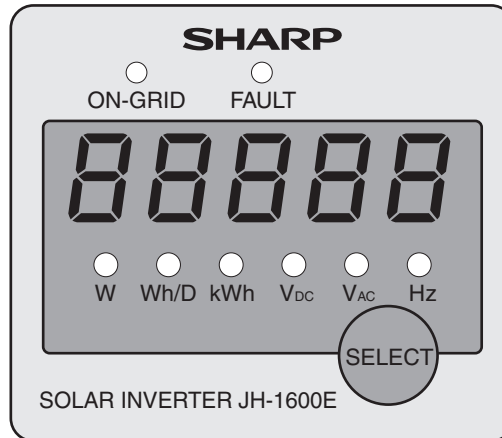

ON-GRID LED (Green)	Flashing = Standby On = ON-Grid
Fault LED (Red)	Fault condition (please see more detail in Error / Fault Code list.)
W LED (Yellow)	Displays instantaneous power (watts)
Wh/D LED (Yellow)	Displays watt-hours today
kWh LED (Yellow)	Displays total kilowatt-hours
V_{DC} LED (Yellow)	Displays input PV array voltage instantaneously
V_{AC} LED (Yellow)	Displays output utility voltage instantaneously
Hz LED (Yellow)	Displays output utility frequency instantaneously
SELECT button	Press to cycle through W, Wh/D, kWh, V _{DC} , V _{AC} , Hz

Status Indicator Lights

The inverter is equipped with two status indicator lights (LEDs) located above the front panel 7 segment LED. These LEDs indicate the inverter current status (the table shown below) and assist in troubleshooting the performance of the unit.

Green	Red	Means
Flash	Off	Standby - reconnecting
On	Off	ON-Grid - operating
Off	On	Fault condition - check code
Off	Off	Sun is down, low DC, no operation

Monitoring the Front Display

Display Flowchart

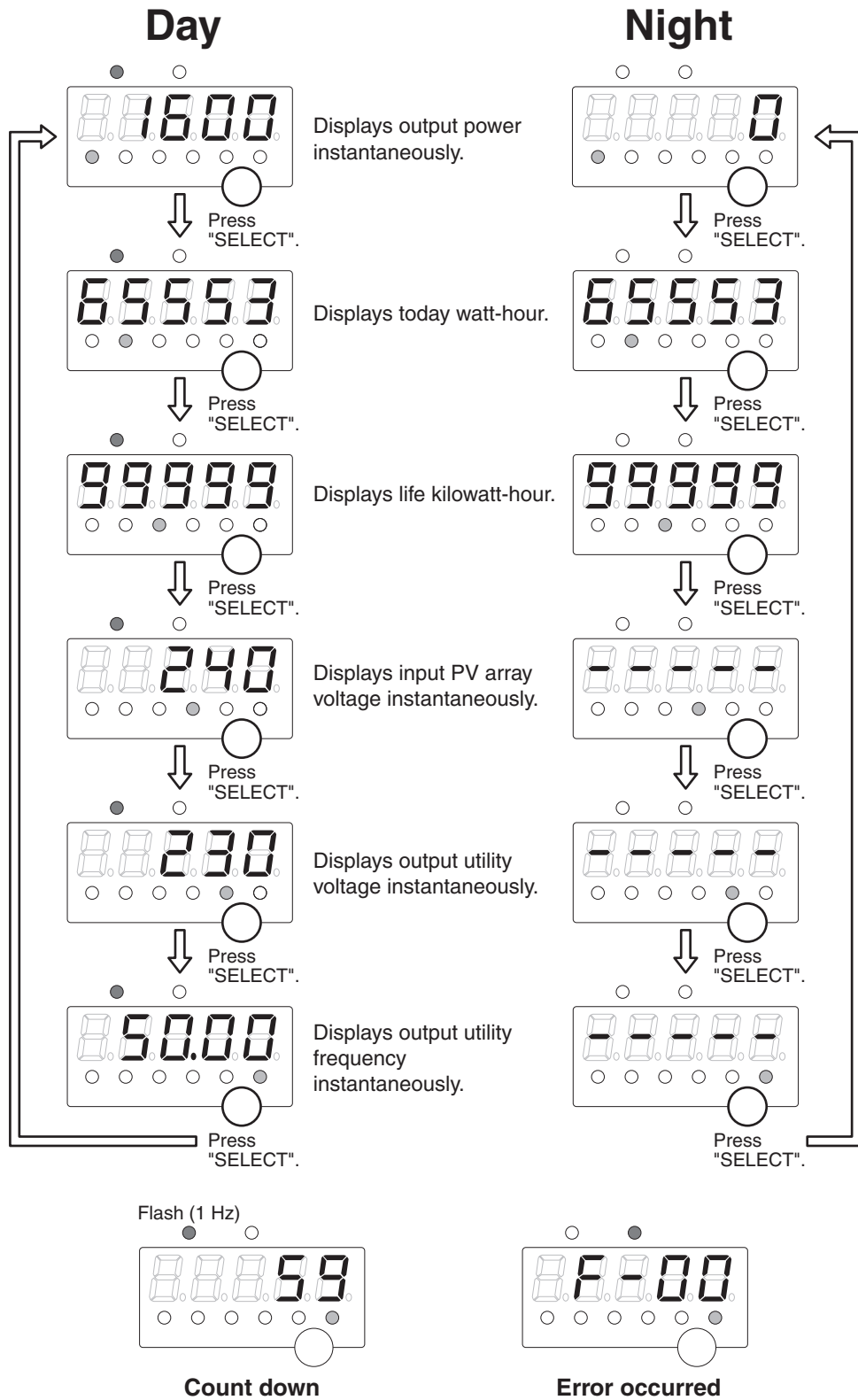

Islanding Protection

The inverter will shut down when the power from the grid becomes abnormal or fails. This will provide safety to the people working on the power lines and protect the home circuits and solar power inverter.

The solar power inverter continually monitors the voltage and frequency of the grid through an internal control circuit. It will detect an abnormal condition or failure of the grid. Abnormal conditions include AC overvoltage, AC undervoltage, AC overfrequency, and AC underfrequency. The solar power inverter shuts down and disconnects from the grid should any of the above conditions occur.

Per AS 4777, the solar power inverter will stop within 2 seconds should the grid voltage be lower than 210 V_{AC} or higher than 255 V_{AC}. The solar power inverter will stop within 1 second should the frequency of the grid be lower than 47 Hz or higher than 53 Hz.

The solar power inverter incorporates two functions to detect and prevent islanding operation. This is important when the output of the inverter and the power consumption of the home are well balanced and the voltage or the frequency of the grid does not change during a power failure, resulting in the power failure not detected. If this occurs, a passive system that detects a jumping voltage phase and an active system that detects frequency shift that stops the inverter operation within 2 seconds.

The solar power inverter display indicates utility abnormal to indicate a power failure.

Error / Fault Code List

Type	Code	Items
Utility abnormal	F-00	Utility over-voltage
	F-01	Utility under-voltage
	F-02	Utility frequency over
	F-03	Utility frequency under
	F-06	Anti-islanding (frequency over)
	F-07	Anti-islanding (frequency under)
	F-08	Miss utility synchronal lock signal
	F-09	Freq. abnormal (50<->60 Hz)
PV array abnormal		PV array under voltage (<60 V)
	P-11	PV array over voltage (>320 V)
Inverter abnormal	E15 → d-15	Relay sticking
	E16 → d-16	Communication error
	E17 → d-17	Aux-power abnormal
	E18	Ground fault
	d-20	Temperature sensor broken
	E21 → d-21	Output over current
	E22 → d-22	DC offset over rating
	E23 → d-23	Fin high temperature
	E26 → d-26	DC/DC converter abnormal
	E27 → d-27	Relay open
	E28	DC bus voltage abnormal
EEPROM	d-40	EEPROM abnormal

Emergency Stop

Turn off the AC disconnect and the DC disconnect when you execute an emergency stop of the inverter.

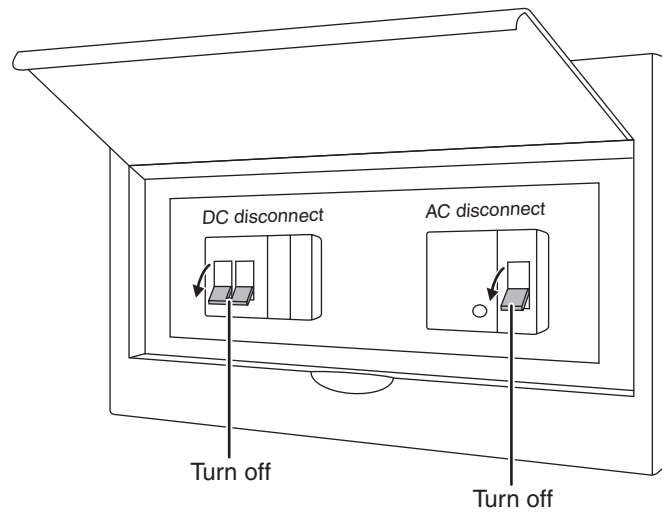

Restart

Turn on the AC disconnect first, and then DC disconnect.
The inverter restarts automatically.

Specification

Electrical Specification

Input	JH-1600E
Absolute maximum array open circuit voltage	350 V _{DC}
Start voltage	Above 70 V _{DC}
Input voltage, operation voltage range	60~320 V _{DC}
Input voltage, MPPT voltage range	60~320 V _{DC}
Input voltage, Maximum power point range*	200~320 V _{DC}
MPPT tracker	1
Maximum input current	8.5 A
Standby mode (In night or No DC power)	230 V _{AC} , 50 Hz, 0.16 A, 1 Watt max.
Output	JH-1600E
Maximum output power	1600 W
Nominal output voltage	230 V _{AC}
Operating range, utility voltage	210~255 V _{AC}
Nominal output frequency	50 Hz
Operating range, utility frequency	47~53 Hz
Nominal continuous output current	7 A
Maximum continuous output current	7.6 A
Output over-current protection	10 A
Maximum utility backfeed current	0 A
Total current harmonic distortion	<5%
Power factor	>0.99
Utility monitoring - islanding protection	V _{AC} , Fac as per AS 4777.2
Output characteristics	Current source
Output current waveform	Sine wave

Environment Specification

Operating temperature range	-20°C~60°C (derating at 40~60°C)
Storage temperature range	-20°C~60°C
Relative humidity	5%~90%
Audible noise	<29 dB-A (1m forward front panel)
Operating elevation	0~2000m (0~6666ft)

Mechanical Specification

	JH-1600E
Outdoor enclosure	Main body IP65 wiring box IP55
Dimensions - without wall mount (H*W*D / mm)	440*348*141 mm
Dimensions - with wall mount (H*W*D / mm)	440*348*153 mm
Shipping dimension (H*W*D / mm)	515*450*290 mm
Inverter weight	12 kg
Shipping weight	15.5 kg
Input connection	From AWG #16 to AWG #10
Output connection	From AWG #16 to AWG #10

Setting item	Setting code	Parameter			
Utility over-voltage parameter (V)	1	250	255	260	---
Utility under-voltage parameter (V)	2	205	210	215	---
Over-voltage /Under-voltage settling time (Sec)	3	1.0	1.4	1.8	---
Utility frequency over parameter (Hz)	4	52	53	54	---
Utility frequency under parameter (Hz)	5	46	47	48	---
Utility frequency over/under settling time (Sec)	6	1.0	1.4	1.8	---
Protection timer (Sec)	7	10	60	150	300
Option *This setting is not used. Do not change the parameter (Leave the value as default of "5").	8	5	One thing at a time	31	---
Operating frequency (Sec)	9	50	60	---	---

Checking Output Power

The output power of the last 7 days (the current day is included) can be checked.
Press "ENT" and "SEL" in the front panel for the operation.

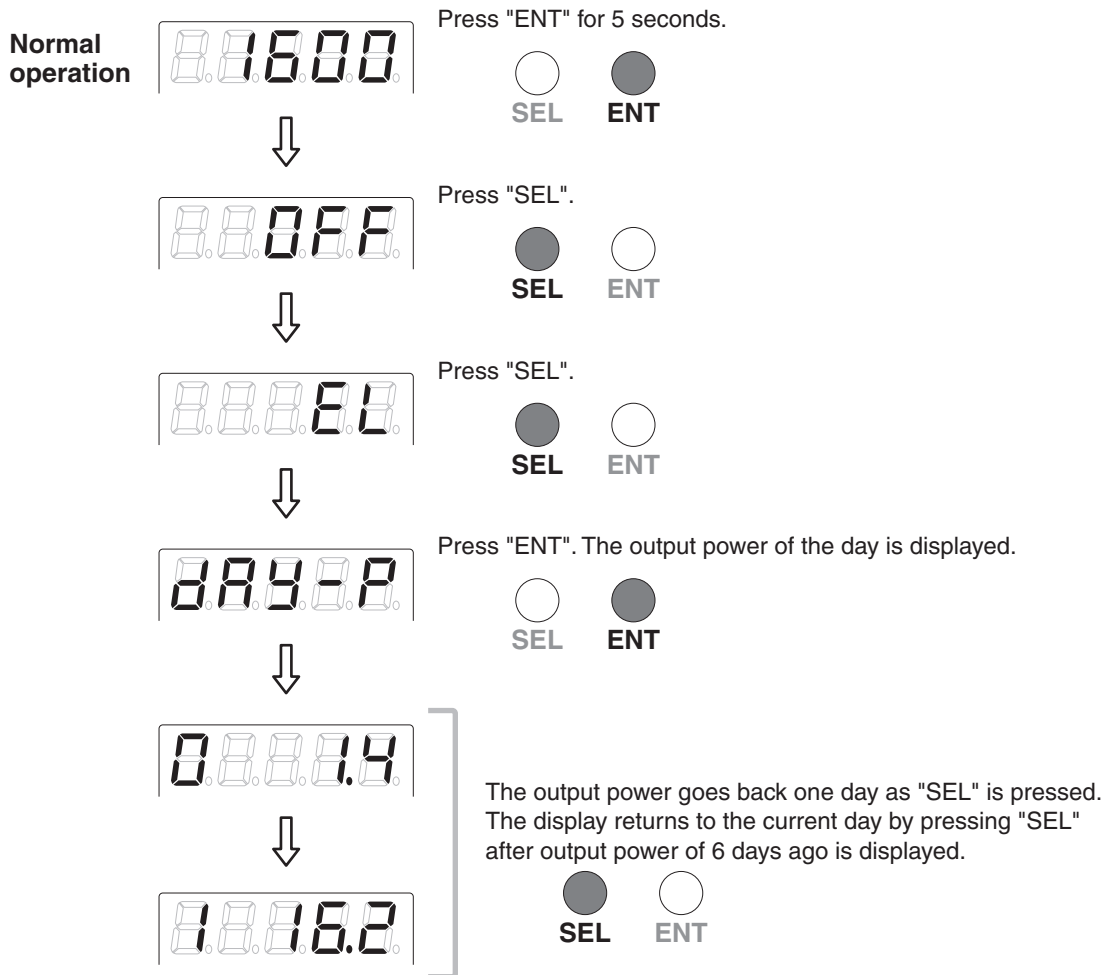

After checking is finished, press "ENT" to display "dAY-P". Then switch displays until "OFF" is displayed. After "OFF" is displayed, press "ENT" for 5 seconds.



Memo

SHARP®

SHARP CORPORATION of Australia

1 Huntingwood Drive, Huntingwood, NSW 2148.
by phone on: 1300 135 022
or by fax on: 1300 727 717

WEB site
<http://www.sharp.net.au/>

SHARP CORPORATION